

SINGLE-CHANNEL GAS MONITOR

RM-6000 series

MODEL

GP-6001	Combustible gases
NC-6001(W)	
SP-6001	Combustible gases
GH-6001	Toxic gases
EC-6002	Toxic gases
OX-6001	Oxygen
OX-6002	
RM-6002	Combustible gases Toxic gases
RM-6003	Oxygen (4-20mA)



FEATURES

- Compact and light weight
- Bar meter and Digital Multi-indication
- Simply fixturable
- Two alarm levels, trouble alarm
- Maintenance mode function
- RoHS Compliant
- Global standard

APPLICATION

- LPG, LNG utilities
- Petro-refinery, Petrochemical plants
- Chemical plants
- Semi-conductor manufacturing plants
- Engineering, public works
- Power station
- Iron and steel works

SPECIFICATIONS

RM-6000 series	GP-6001 NC-6001(W)	SP-6001	GH-6001	EC-6002	OX-6001	OX-6002	RM-6002	RM-6003
Detection gas	Combustible	Combustible / Toxic		Toxic	Oxygen		Combustible / Toxic / Oxygen	
Indication	3-color LCD bar meter (52 dots)							
Type of acceptable detector head	Catalytic combustion/ New ceramic type	Hot-wire semiconductor type	Semiconductor type	Electrochemical type	Galvanic cell type		4-20mA outputs	
							2-wire type	3-wire type
Acceptable input signal	Direct sensor signal			4-20mA output	Direct sensor signal	4-20mA output		
Applicable cable	CVW-4C		CVVS-3C	CVVS-2C			CVVS-3C	
Max distance	Max 1.0km		Max 1.0km	Max 2.0km	Max 600m	Max 2.0km		
Output signal	Output of electric power transmission (non-isolated) 4-20mADC, max loop load 300 ohm							
Alarm indication	Flashing or lighting lamp: Red(AL1), Red (AL2), Latching or non-latching, Locking mode							
Fault alarm	Orange lamp flashing (FAULT), Non-latching							
Alarm relays	Normally energized or de-energized, Normally-open or close contact Rated 1A at 125VAC, 1A at 30VDC (resistive)							
Operation condition	-10 – 50 °C, below 95%RH (non-condensing)							
Power requirement	AC type: 100 – 240 VAC +/-10% DC type: 24VDC +/-10%							
Power consumption*	Max 15VA MAX 8.5W		Max 11.5VA MAX 6W	Max 7.5VA MAX 3.5W	Max 6.5VA MAX 3W	Max 7.5VA MAX 3.5W		
Dimensions & Weight	Approx. 110 (W) x 190 (H) x 54 (D) mm, Wall mounting type: 580g / Panel mounting type: 650g							
Mounting	Wall mounting type / Panel mounting type							

*The power consumption value does not include that of the connected detector head.

Specification subject to change without notice.

COMPONENT DESIGNATIONS

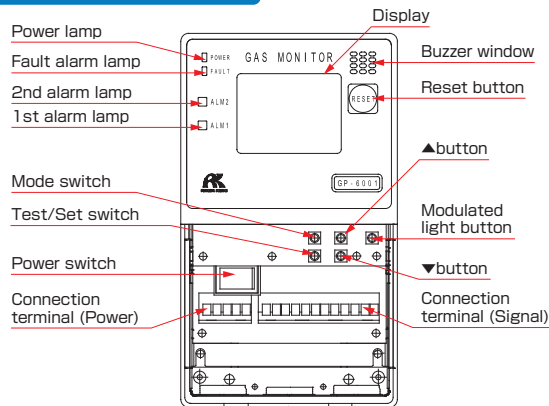

INDICATION

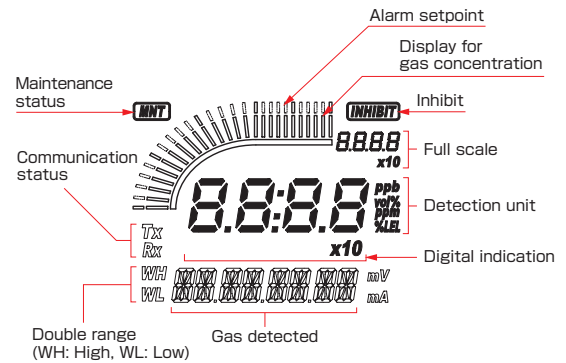

OUTER DIMENSIONS

[Wall mounting]

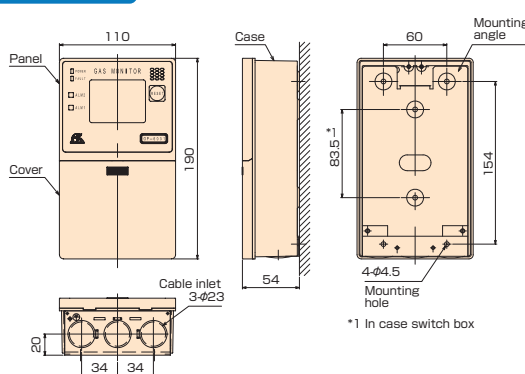

[Panel mounting]

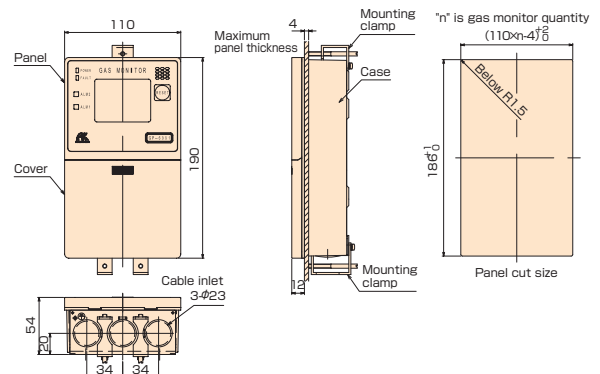

★ Distributed by:

RIKEN KEIKI Co., Ltd.

2-7-6 Azusawa, Itabashi-ku, Tokyo 174-8744, Japan

Phone : +81-3-3966-1113

Telefax : +81-3-3558-9110

E-mail : intdept@rikenkeiki.co.jp

Web site : <http://www.rikenkeiki.co.jp/english>